

SPECIAL FEATURES

- Standard Followed ASME-B 40.1 / EN837-1
- Cost Effective
- Build in Stabilizer Movement
- Dry or Liquid Version
- Ready For Oxygen Service
- IP 65

SPECIFICATIONS

- Ambient Temperature: -4°F (-20°C) to + 150°F(+65°C)
- Process Temperature: Max.248°F (120°C)
- Operating Pressure Range: 75% of Scale Value
- Over Pressure Limit: 125% of Max. Scale Value
- Case: AISI 304 SS
- Joints: Alloy brazing/Soldering
- Socket: Copper Alloy
- Bourdon: Copper Alloy
- Movement: Copper Alloy
- Dial: Aluminum
- Pointer: Fixed
- Window: PC lens
- Range: Vacuum to 6000 psi



ACCURACY AS PER ASME B.40.1

1.5"/2" 3-2-3 GRADE B)

2.5"/3"/4" : 2-1-2 GRADE A)

*Please consult factory for better accuracy availability.

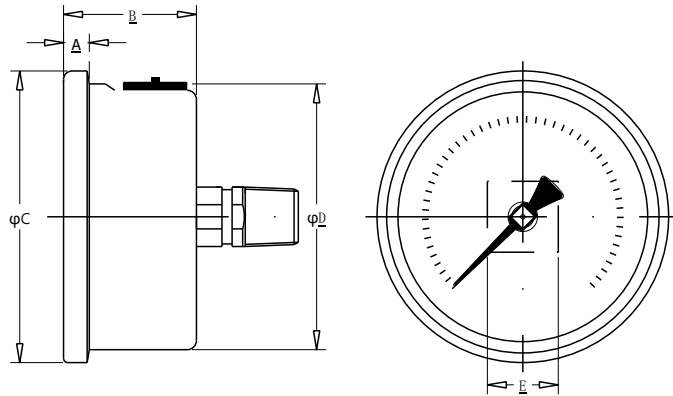
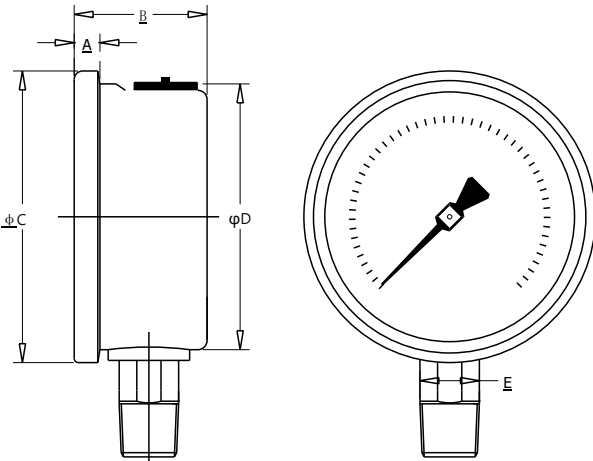

	NS	NS	A	B	φC	φD	E	Weight (lbs)
Crimped type	1.5"	0.2"	1"	1.84"	1.6"	0.43"	0.18	
	2"	0.24"	1.16"	2.3"	2"	0.55"	0.26	
	2.5"	0.24"	1.22"	2.68"	2.44"	0.55"	0.40	
	3"	0.27"	1.37"	3.43"	3"	0.67"	0.60	
	4"	0.32"	1.85"	4.3"	4"	0.87"	1.32	
Bayonet type	2.5"	0.5"	1.4"	2.68"	2.44"	0.55"	0.40	
	3"	0.43"	1.4"	3.5"	3.15"	0.67"	0.60	
	4"	0.5"	1.87"	4.4"	4"	0.87"	1.32	

	NS	NS	A	B	φC	φD	E	Weight (lbs)
Crimped type (CBM)	1.5"	0.2"	1"	1.74"	1.6"	0.43"	0.18	
	2"	0.24"	1.16"	2.3"	2"	0.55"	0.26	
	2.5"	0.24"	1.22"	2.68"	2.44"	0.55"	0.40	
	3"	0.27"	1.37"	3.43"	3"	0.67"	0.60	
Bayonet type (LBM)	2.5"	0.5"	1.4"	2.68"	2.44"	0.55"	0.40	
	3"	0.47"	1.4"	3.3"	3"	0.55"	0.60	
	4"	0.5"	1.87"	4.4"	4"	0.87"	1.32	

HOW TO ORDER

NOMINAL SIZE

B	C	D	E	F
1.5"	2"	2.5"	3"	4"

Example

X

TYPE OF MOUNTING

- 1 WALL/SURFACE/PROJECTION MOUNTING WITH BOTTOM
- 2 BOTTOM
- 3 LOWER BACK
- 5 LOWER BACK WITH FRONT FLANGE
- 6 LOWER BACK WITH MOUNTING BRACKET
- 7 CENTER BACK WITH FRONT FLANGE
- 8 CENTER BACK WITH MOUNTING BRACKET

X

GAUGE CONNECTION

- 2BM** 1/4" BSP(M)
- 2NM** 1/4" NPT(M)
- 3BM** 3/8" BSP(M)
- 3NM** 3/8" NPT(M)
- 4BM** 1/2" BSP(M)
- 4NM** 1/2" NPT(M)
- 4MM** M20 X 1.5(M)

***Please consult factory for any special connections

XXX

RANGE

CODE	E1	E2	E3	E4	E5	E6	E7	E8	E9	E10	E11	E12	E13
RANGE (psi)	-30"hg	-30"hg-15	-30"hg-30	-30"hg-60	-30"hg-100	-30"hg-160	-30"hg-200	-30"hg-300	15	30	60	100	160
CODE	E14	E15	E16	E17	E18	E19	E20	E21	E22	E23	E24	E25	E26
RANGE (psi)	200	300	400	500	600	800	1000	1500	2000	3000	4000	5000	6000

E13

OPTIONAL EXTRAS

- | | |
|---|---|
| SG OXYGEN SERVICE (FOR DRY VERSION) | CK EPOXY PAINTED CASE & BEZEL |
| OA ACCURACY + 0.5% OF F.S. | SQ CASE WITH ROLLING TYPE BEZEL |
| SF MOVEMENT WITH DAMPENING JELLY | OS CASE WITH BAYONET TYPE BEZEL |
| RI 25mm BOD | PS AISI 316 SS CASE & BEZEL |
| SI KNIFE EDGE POINTER | KA ON-OFF TYPE VENT PLUG |
| FN 2" PIPE/YOKE MOUNTING BRACKET & 'U' CLAMP (AISI 316 SS) | SX SS TAG PLATE |
| RG ANTI PARALLAX MIRROR BAND DIAL | SY AISI 316SS TAG PLATE |
| RH CUSTOM DESIGNED DIAL | FK INTEGRAL DAMPENING SCREW (BRASS) |
| ZB RECEIVER RANGE | FS FILLABLE LIQUID SILICON OIL |
| AT ATEX (AS PER 2014/34/EU) | FG FILLABLE LIQUID GLYCERINE |
| ZC FREON RANGE (WITH TEMPERATURE SCALE) | ZZ DIELECTRIC OIL FILLED |
| ZD AMMONIA RANGE (WITH TEMPERATURE SCALE) | PX DAMPENING LIQUID FLOUROLUBE FILLED |
| SW DIAL TAG MARKING | PY DAMPENING LIQUID GLYCERINE OIL FILLED |
| RW PLEXI GLASS | PZ DAMPENING LIQUID MINERAL LIQUID FILLED |
| SJ MAXIMUM READING POINTER WITH PLEXI GLASS | QA DAMPENING LIQUID SILICON OIL FILLED |
| SJ FILLABLE VERSION | GH MATERIAL TEST CERTIFICATES |
| ZM ELECTRO POLISHED CASE & BEZEL | PW FIVE POINT CALIBRATION CERTIFICATE NATIONAL/INTERNATIONAL STANDARDS |

XX

Ordering Example: P-16-X-X-XXX-(E13)-XX