

## SPECIAL FEATURES

All SS 316 Construction  
Ideal for Slurry / High Viscous fluids.  
Flange & Diaphragm are available in various type of SS & Exotic Materials.

## SPECIFICATIONS

Range: 1 kg/cm<sup>2</sup> to 250 kg/cm<sup>2</sup>\*  
Process Temperature: -40°C to 200°C or as per fill fluid  
Instrument Connection: 1/2"NPT(F)  
Process Connection: Flange (Refer Table)  
Flange Finish: Finish 125-250 AARH  
Diaphragm: AISI 316L SS  
Body: AISI 316 SS  
Flange: AISI 316 SS  
Extension: 50mm (Other extension on request)  
Fill Fluid: Silicon Oil -DC 200

## APPLICATIONS

Diaphragm seals are provided in the Instrument like Pressure Gauges ,Switches, Transmitters in order to isolate the sensing element from the main service due to It's Corrosive ,Viscous and Sedimented nature and to avoid clogging and solidification. These kind of seals are widely used in the Viscous & Corrosive services where flushing is required periodically & frequently.

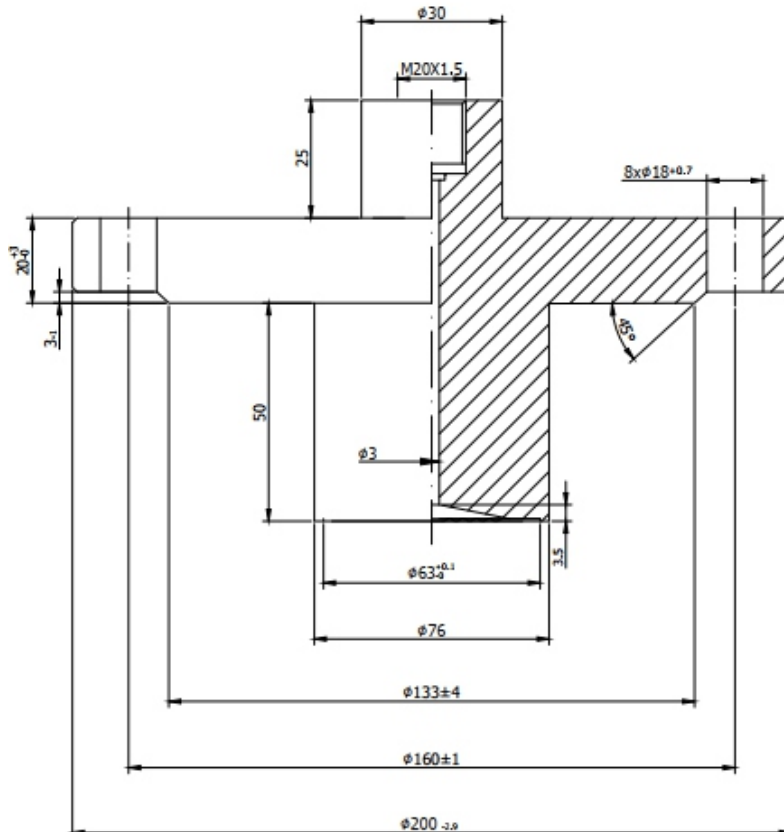

## HOW TO ORDER

### BASIC MODEL

Example

D-11

### INSTRUMENT CONNECTION

**VP** 3/8"BSP(F)    **VL** 1/2"BSP(F)    **VM** 1/2"NPT(F)(Standard)

XX

### DIAPHRAGM

**UJ** AISI 316L SS (Standard)    **UL** HASTELLOY 'C'    **UM** MONEL

XX

### BODY

**CN** MONEL    **CO** HASTELLOY 'C'    **CM** AISI 316L SS    **CL** AISI 316 SS (Standard)

XX

### BODY LENGTH (Standard: 50mm & Max. Up to 200mm)

Specify IN mm (e.g 50mm, 100mm, 150mm & 200mm)

100mm

### PROCESS CONNECTION

As per DIN / BS / ANSI / JIS (Select Code from Flange Table.Refer Page No.25 & 26)

XX

### FLANGE MATERIAL

**TL** AISI 316L SS    **TX** MONEL    **TT** HASTELLOY C    **TM** AISI 316 SS (Standard)

XX

### PROTECTION ON WETTED PARTS

**VZ** PTFE COATING ON DIAPHRAGM (Max.Up to 315°C)

XX

### FILLING LIQUID (\*Consult factory for specifications , price and delivery)

**US** FLUROLUBE 4.2 [-45 to 175°C]    **UX** SILICON DC 200[-40 to 205°C]<sup>(Standard)</sup>    **VB** SYL THERM XLT [-100 to 260°C]  
**UT** FLUROLUBE 6.3 [-40 to 235°C]    **UY** SILICON DC 704 [10 to 337°C]    **VC** HALOCARBON OIL\*  
**UU** FLUROLUBE FS-5 [-28 to 148°C]    **UZ** SILICON DC 710 [7 to 371°C]  
**UV** FOOD GRADE OIL [-20 to 140°C]    **VA** SYL THERM 800 [-40 to 315°C]

XX

### REMOTE MOUNTING (With Capillary of Max. Up to 15 Mtrs.)

SPECIFY IN METERS (e.g 1.5=1.5 METERS 2.0=2 METERS)

3Mtr.

### CAPILLARY

**PE** AISI 304 SS    **PG** AISI 316 SS

XX

### CAPILLARY COVERED WITH ARMOUR (Applicable with PE or PG if selected)

**PF** AISI 304 SS    **PH** AISI 316 SS    **PI** PVC

XX

### OTHER OPTIONS

**TB** HELIUM LEAK TEST    **TC** DRY SEAL ONLY WITHOUT INSTRUMENT    **GH** MATERIAL TEST CERTIFICATE\*

XX

**Ordering Example: D-11-XX-XX-XX-100mm-XXX-XX-XX-XX-3 Mtr-XX-XX-XX**